

Cast iron Gate Valve outside screw brass trim PN10 handwheel operated High Temperature

Main characteristics

- Manufactured in Italy in accordance with EN 1171
- Face-to-face length according to EN 558-1, basic series 14
- Flanged according to EN 1092-2 PN10 with raised face, undrilled, PN16 or other specifications on request
- Outside screw thread clockwise closing, adjustable stuffing box
- Minimal pressure drop
- Hydrostatically tested according to EN 12266-1: Test type P11-P12 Rate A
- Pressure Equipment Directive 2014/68/UE Group 2
- 100% full bore
- Gate valves are bi-directional and can be installed in any position. However, the preferred orientation is with the stem pointing vertically upwards.

Field of application

- Industrial plants
- Sewage Water
- Water treatment
- Air-conditioning systems (HVAC)
- Central heating and cooling circuits
- Non-aggressive fluids
- Tanks
- Fire sprinkler systems

Corrosion protection

- Standard version: externally coated with Phenolic-oil resin with zinc-phosphate high corrosion resistance painting Grey Ral 7011
- On request: integrally epoxy coated
- Customized color available



Ratings

Working temperature (°C)	-10 to +120	+120 to +150
Max Working pressure (bar)	10	8

Hydrostatically tested according to EN 12266-1 (bar)

P11 Body test	P12 Seat Test water	P12 Seat test air
15	11	6

Material specification

Nr	Parts	Material	Specification
1	Lock nut	CW614N Drawn brass	EN 12164
2	Handwheel	EN-GJL-250 grey cast iron	EN 1561
3	Motherscrew	CB 754-S GM Cast brass	EN 1982
4	Yoke	EN-GJL-250 grey cast iron	EN 1561
5	Packing gland	EN-GJL-250 grey cast iron	EN 1561
6	Packing	Ptfe	ASTM 4894
7	Gasket	Fasit 205	-
8	Stem	CW614N Drawn brass	EN 12164
9	Bonnet	EN-GJL-250 grey cast iron	EN 1561
10	Gasket	Fasit 205	-
11	Motherscrew	CB 754-S GM Cast brass	EN 1982
12	Wedge DN 40-DN 100	CB 754-S GM Cast brass	EN 1982
12	Wedge DN 125-DN 300	EN-GJL-250 grey cast iron	EN 1561
13	Seat	CB 754-S GM Cast brass	EN 1982
14	Body	EN-GJL-250 grey cast iron	EN 1561
15	Nut	Zinc-plated 8.8 carbon steel	ISO 4032
16	Screw	Zinc-plated 8.8 carbon steel	EN ISO 4017
17	Tie rod	Zinc-plated 8.8 carbon steel	-
18	Pin	Carbon steel	-

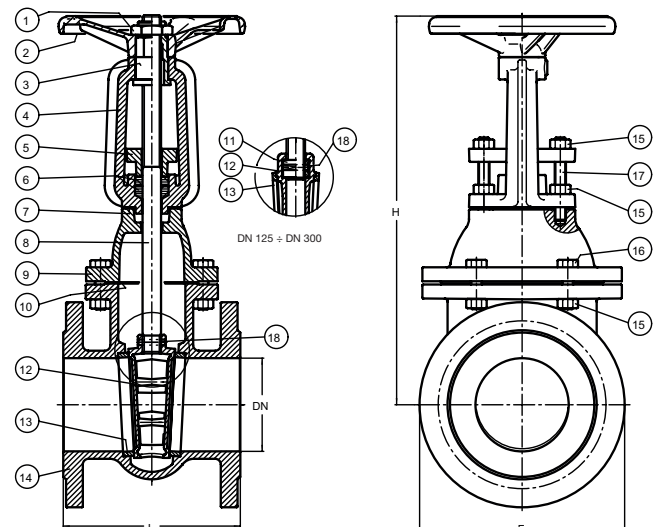

Technical data

DN	40	50	65	80	100	125	150	175	200	250	300
F mm	150	165	185	200	220	250	285	315	340	395	445
L mm	140	150	170	180	190	200	210	220	230	250	270
H mm	265	275	335	355	400	495	585	660	700	830	960
Weight Kg	10	12	16	20	26	33	43	55	72	100	134
Handwheel Ø mm	150	150	175	175	200	200	225	225	225	250	300
Turns open/close nr	10	12,5	16	20	25	25	30	35	40	50	60
Max torque gate closing Nm	30	30	35	35	40	45	45	60	60	65	70
Kvs value	107	250	430	790	1.250	1.960	2.790	2.800	2.880	4.306	6.380

EN_110ht - Edition 09/2017 • Maran e Peracini srl assumes no responsibility or liability for typographical errors or omissions and reserves the right to change without notice.